



Que-2-TXT™  
Questions?  
scan to text us fast



# F18 PLASTIC LED SIGN RETROFIT LAMP

DOUBLE SIDE LIT, HIGH BRIGHTNESS

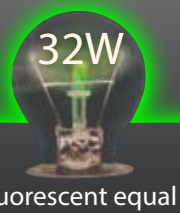

## specifications

Voltage	CRI	BASE	Lens	Heat Sink	L70 hours	Ambient Temp (F)	Power Factor	IP Rating	THC	Beam Angle
⚡ 100-277 V	83	R17D	double-side plastic	aluminum	50,000	-22°- 131°	>0.9	IP 64 except for base	<15%	360°

## select your lamp

Part Number	Color Temp	Consumption	Lumen Output	Efficacy	Length (pin to pin)	Diameter
GH-F18T10-CC32-R17D4	6000K	9W	1,170	130 lm / w	15.91"	1.28"

Warranty	Weight	Case QTY
6 years	0.66 lbs	10 pcs

- ### Features
- ▶ Rotatable base
  - ▶ Rated for fully enclosed fixtures
  - ▶ 50,000 hour LED lifespan based on IES LM-80 results and TM-21 calculations
  - ▶ Double-side powered
  - ▶ Designed for double sided signs
  - ▶ Replaces F18T12/HO lamps



## Installation Diagram

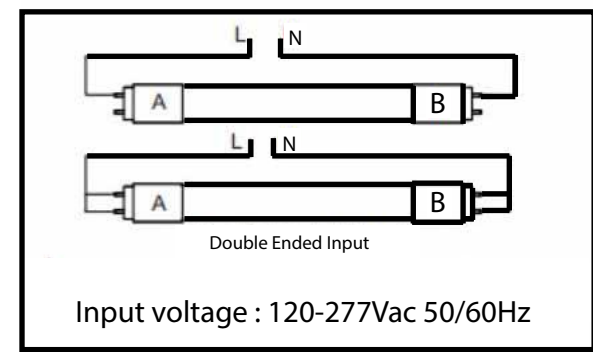

/greenignite  
@greenignite



www.greenignite.com



info@greenignite.com



1-877-560-3779



Que-2-TXT™  
Questions?  
scan to text us fast



# F24 PLASTIC LED SIGN RETROFIT LAMP

DOUBLE SIDE LIT, HIGH BRIGHTNESS



## specifications

Voltage	CRI	BASE	Lens	Heat Sink	L70 hours	Ambient Temp (F)	Power Factor	IP Rating	THC	Beam Angle
⚡ 100-277 V	83	R17D	double-side plastic	aluminum	50,000	-22°- 131°	>0.9	IP 64 except for base	<15%	360°

## select your lamp

Part Number	Color Temp	Consumption	Lumen Output	Efficacy	Length (pin to pin)	Diameter
GI-F24T10-CC35-R17D4	6000K	12W	1,560	130 lm / w	21.91	1.28"

Warranty	Weight	Case QTY
6 years	0.86 lbs	10 pcs

## Features

- ▶ Rotatable base
- ▶ Rated for fully enclosed fixtures
- ▶ 50,000 hour LED lifespan based on IES LM-80 results and TM-21 calculations
- ▶ Double-side powered
- ▶ Designed for double sided signs
- ▶ Replaces F24T12/HO lamps



## Installation Diagram

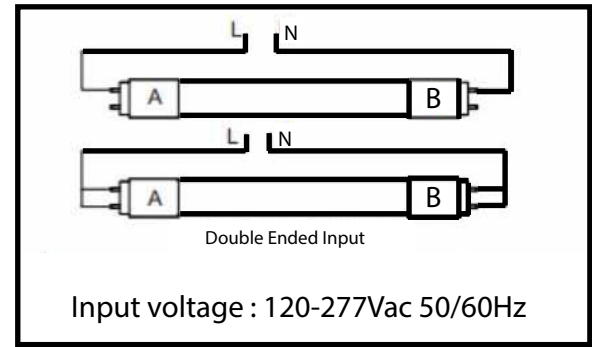

/greenignite  
@greenignite



www.greenignite.com



info@greenignite.com



1-877-560-3779



Que-2-TXT™  
Questions?  
scan to text us fast



# F30 PLASTIC LED SIGN RETROFIT LAMP

DOUBLE SIDE LIT, HIGH BRIGHTNESS

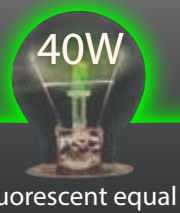

## specifications

Voltage	CRI	BASE	Lens	Heat Sink	L70 hours	Ambient Temp (F)	Power Factor	IP Rating	THC	Beam Angle
⚡ 100-277 V	83	R17D	double-side plastic	aluminum	50,000	-22°- 131°	>0.9	IP 64 except for base	<15%	360°

## select your lamp

Part Number	Color Temp	Consumption	Lumen Output	Efficacy	Length (pin to pin)	Diameter
GI-F30T10-CC40-R17D4	6000K	14W	1,820	130 lm / w	27.91	1.28"

Warranty	Weight	Case QTY
6 years	1.06 lbs	10 pcs

- ### Features
- ▶ Rotatable base
  - ▶ Rated for fully enclosed fixtures
  - ▶ 50,000 hour LED lifespan based on IES LM-80 results and TM-21 calculations
  - ▶ Double-side powered
  - ▶ Designed for double sided signs
  - ▶ Replaces F30T12/HO lamps



## Installation Diagram

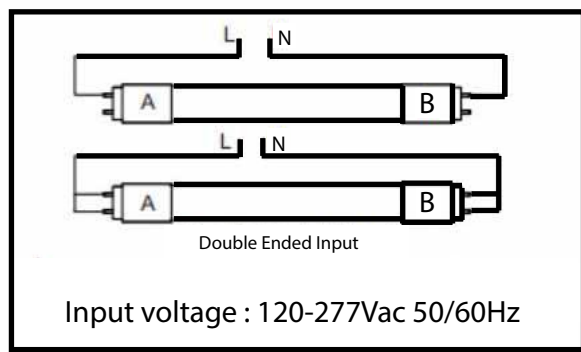

/greenignite  
@greenignite

[www.greenignite.com](http://www.greenignite.com)

[info@greenignite.com](mailto:info@greenignite.com)

1-877-560-3779